

NOTES:
1. SEE DETAIL 20/SD.1 FOR ANCHORAGE REQUIREMENTS.
2. WSW-RT SHOWN; WSW-RTPP & WSW-RTBL SIMILAR

21 WSW TEMPLATE

22 CONT. CONCRETE FOOTING FOR EXT. STUD WALL

23 6" STEM WALL

24 ROOF TRUSSES AT GIRDER

LEI
- A Utah Corporation -
ENGINEERS
SURVEYORS
PLANNERS
3302 N. Main Street
Spanish Fork, UT 84660
Phone: 801.798.0555
Fax: 801.798.9393
office@lei-eng.com
www.lei-eng.com

Professional Engineer
Eric C. Murray
No. 66953
Signed: 09/17/2020
EXPIRES: 09/17/2025

STRUCTURAL ELEMENTS ONLY

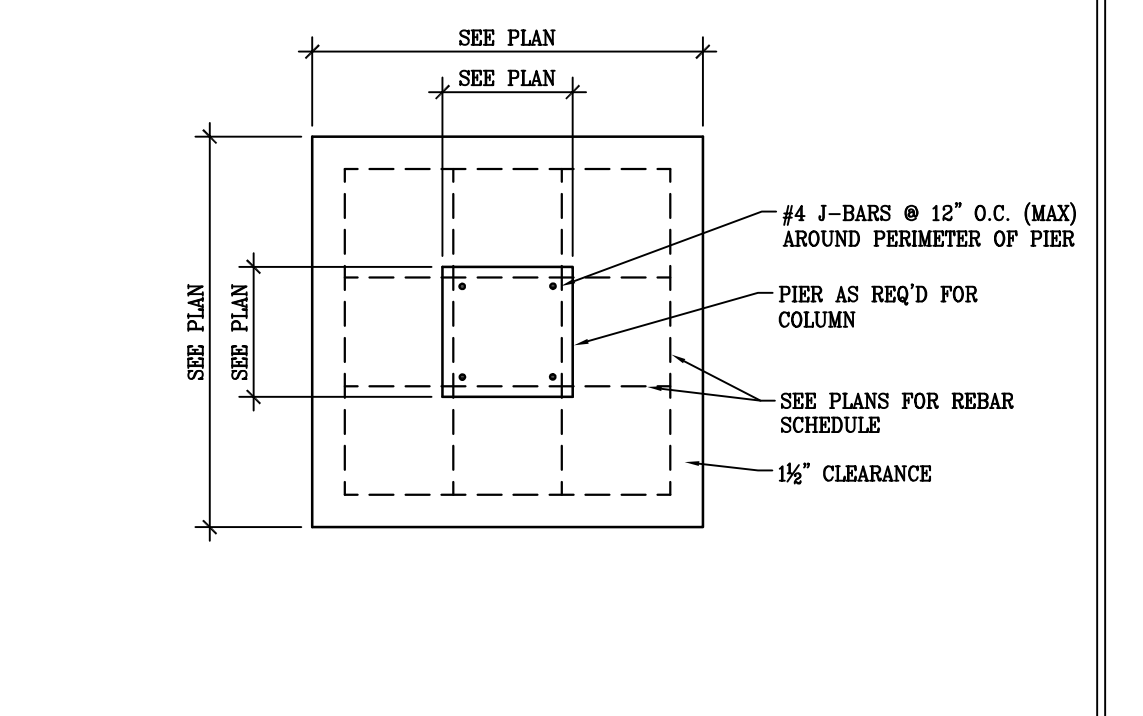
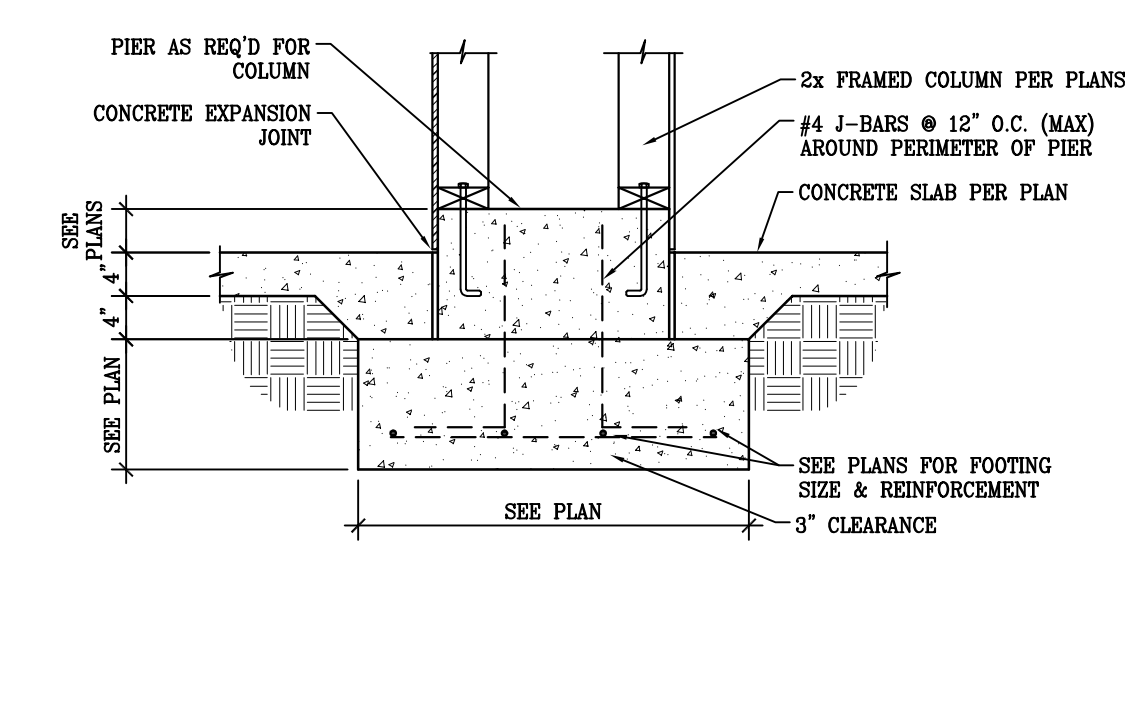
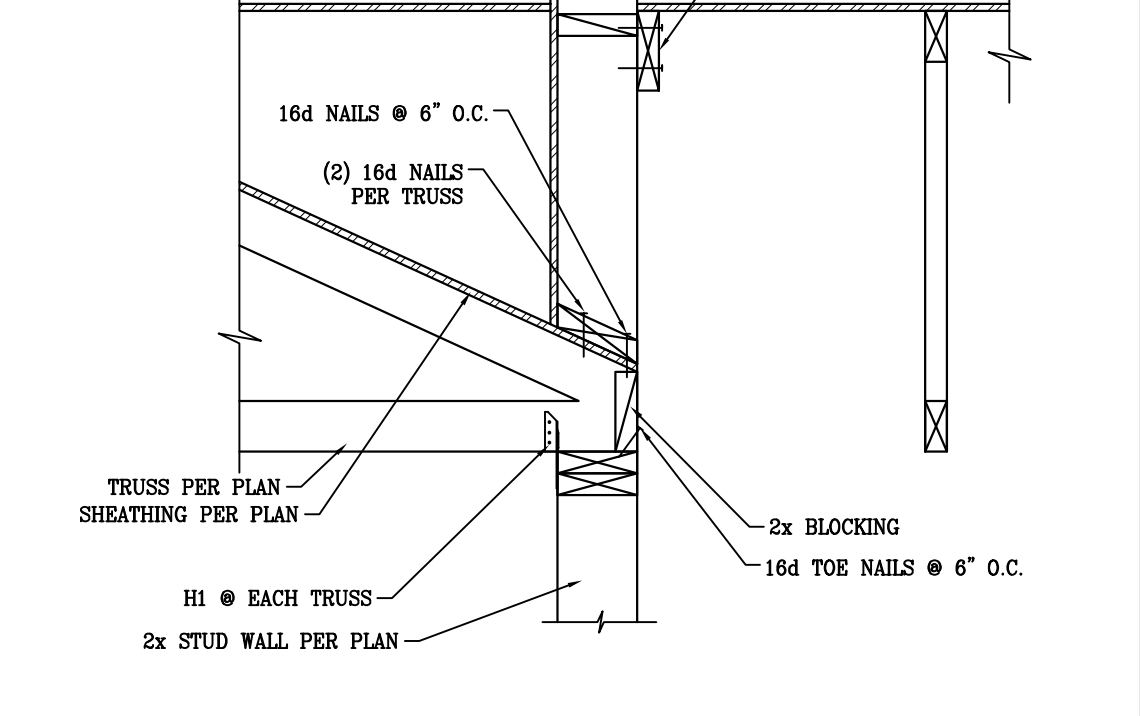
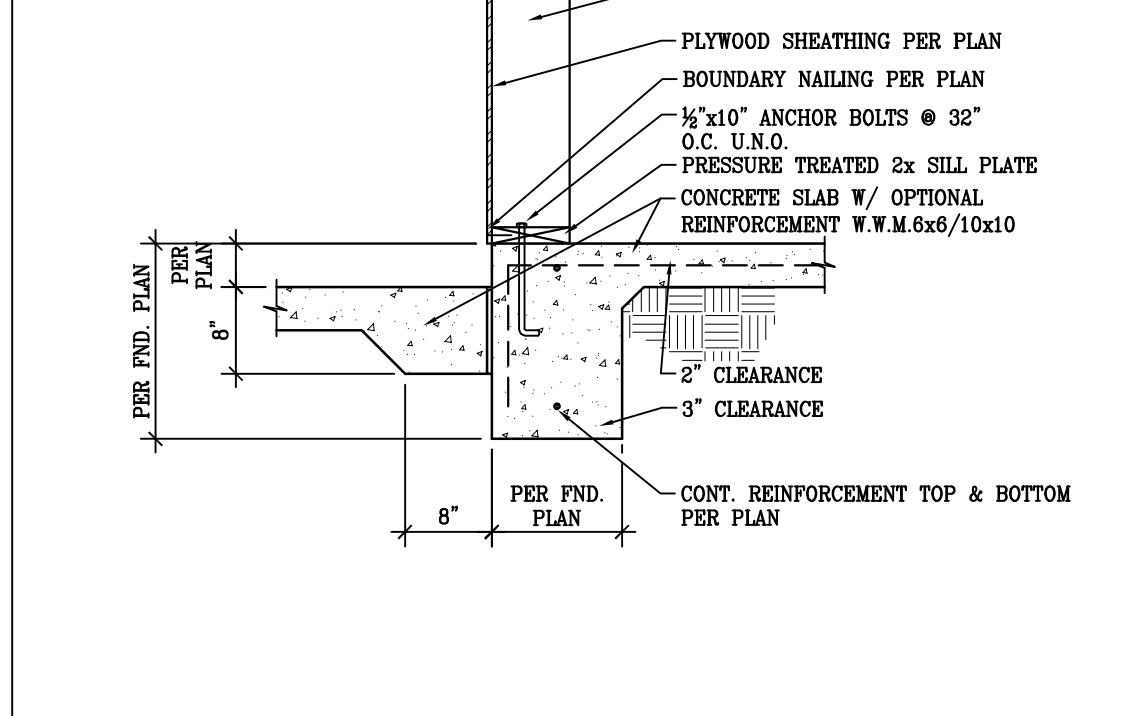
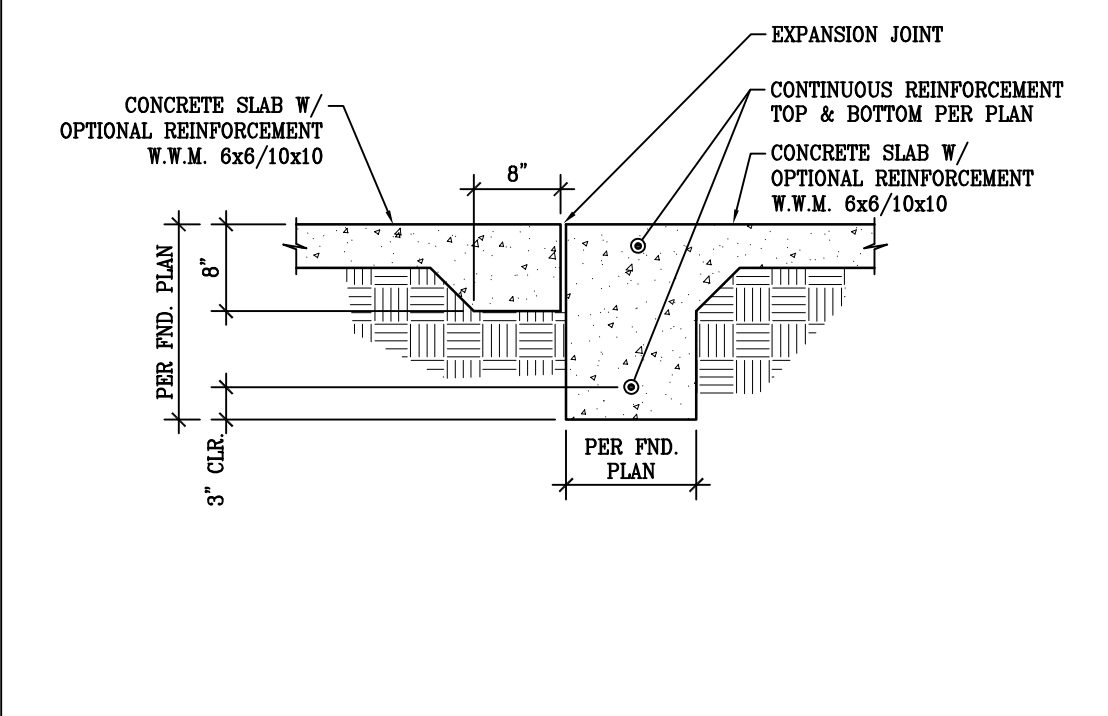

26 CONT. CONC. FOOTING @ GARAGE FRONT DOOR

27 CONT. CONCRETE FOOTING ADJACENT TO CONC. SLAB

28 SHARED WALL

29 PIER FOOTING DETAIL

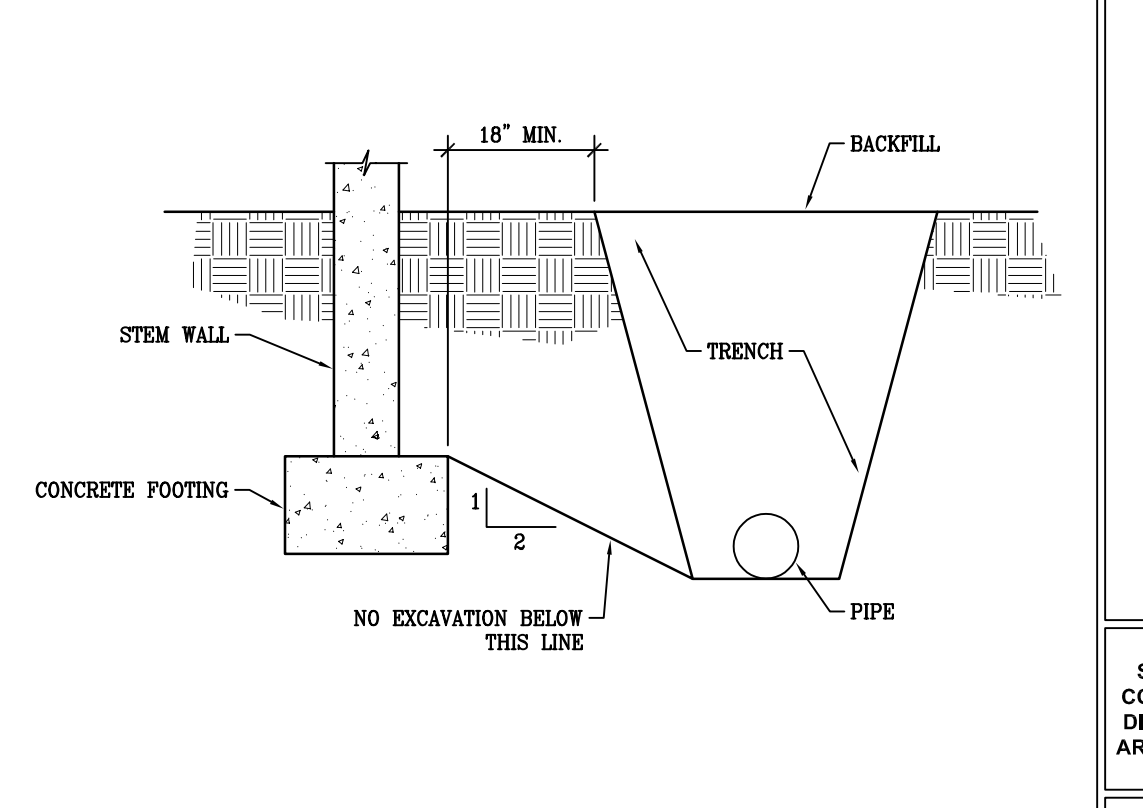
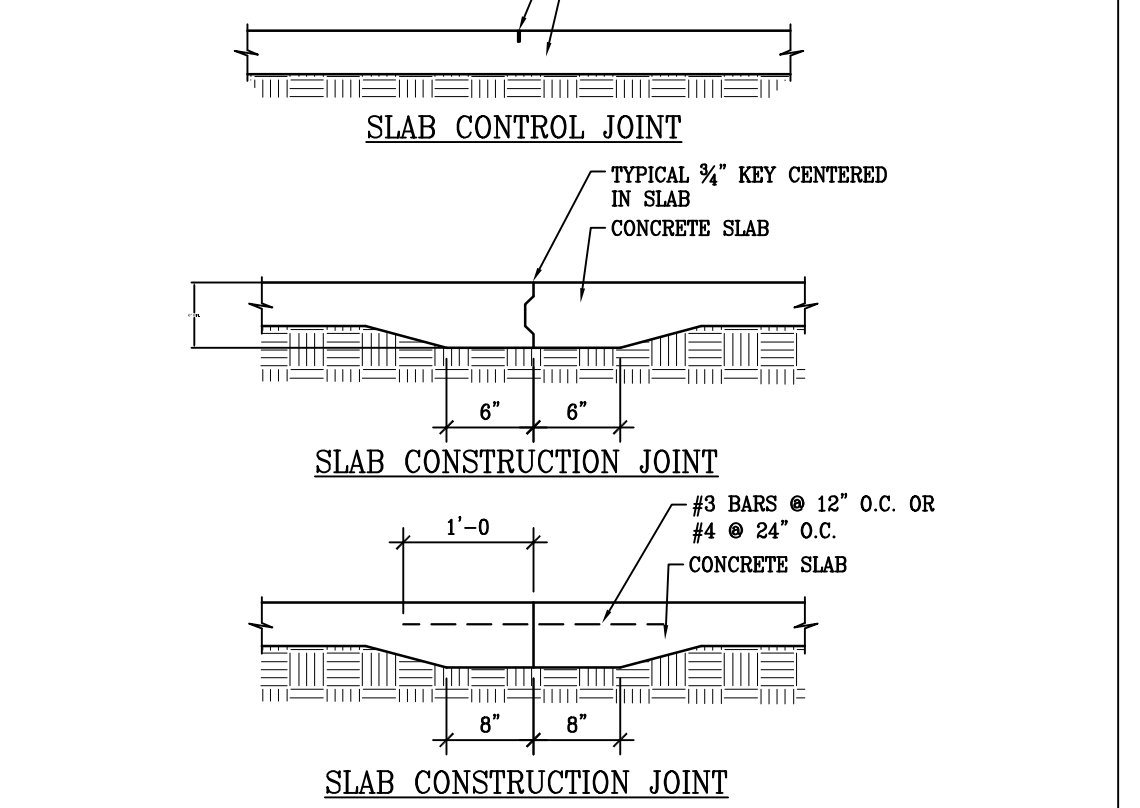
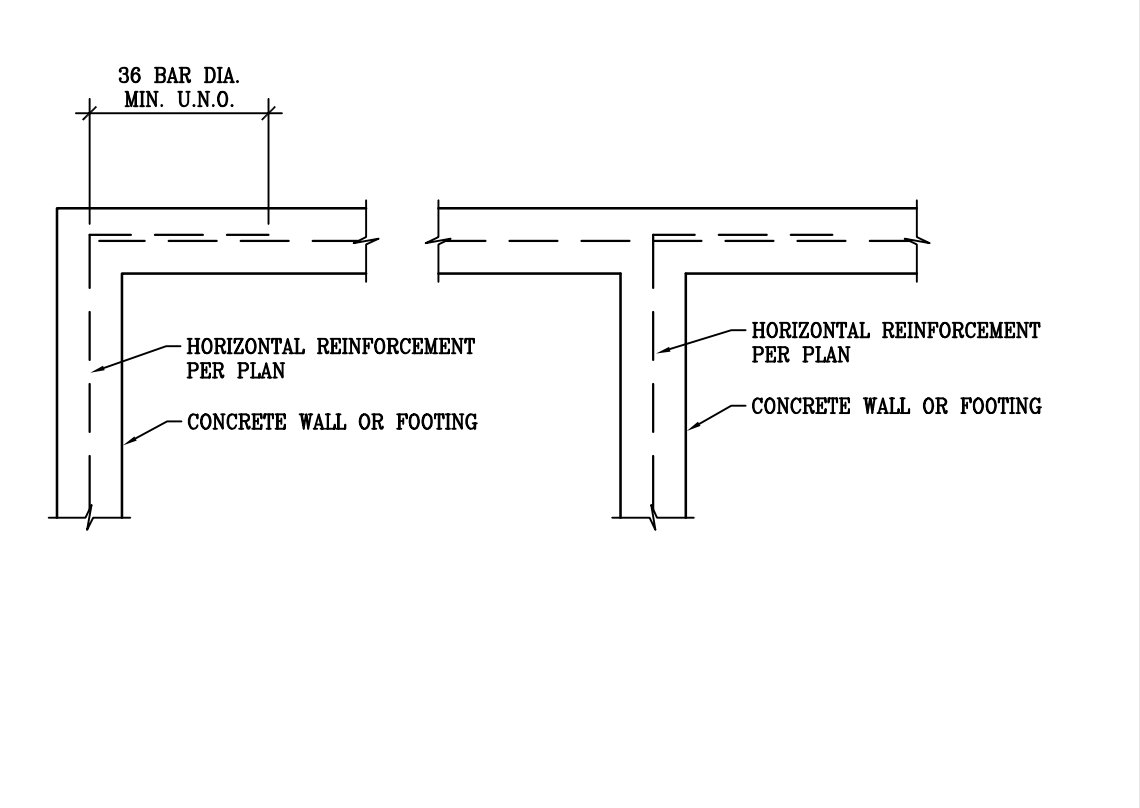
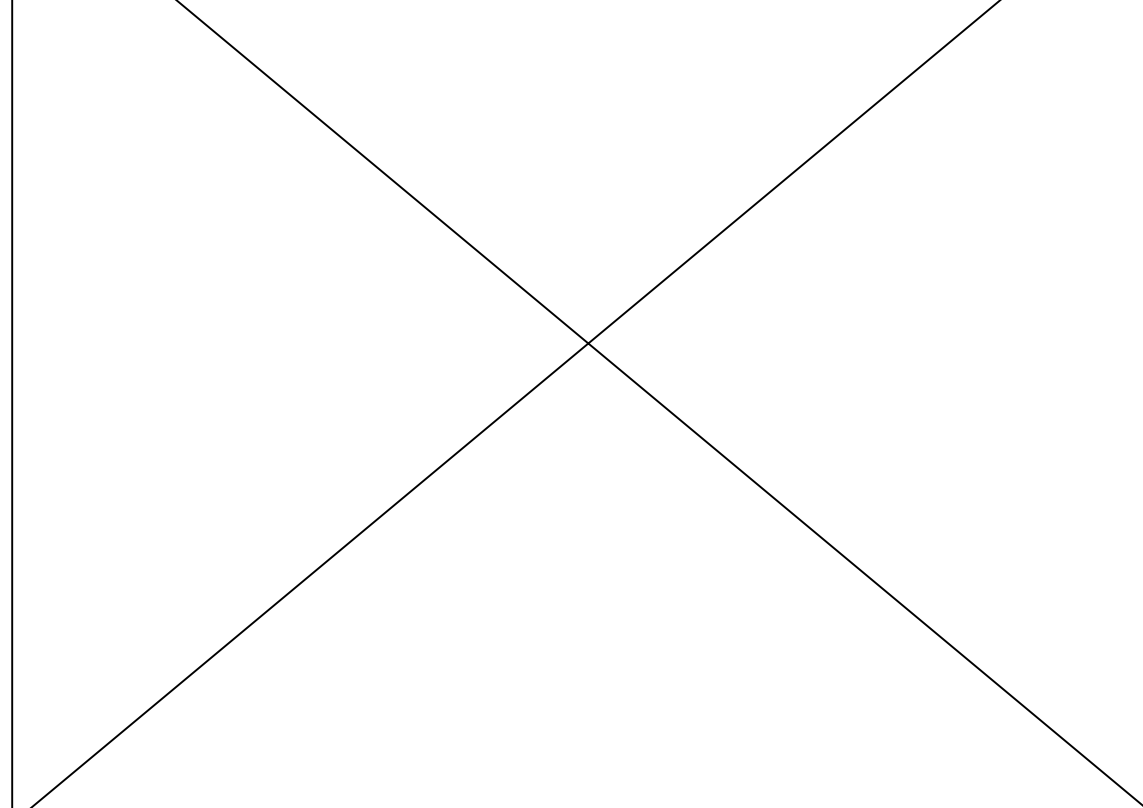
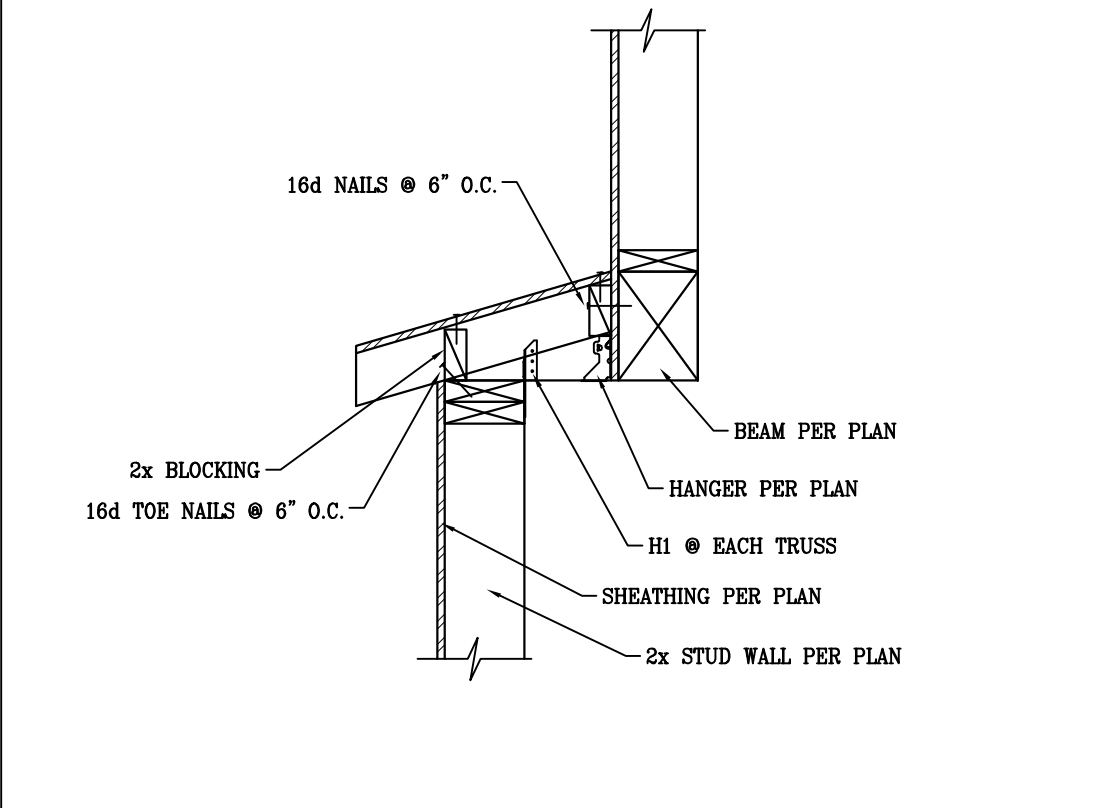

30 TRUSS TO BEAM CONNECTION

31 NOT USED

32 CONC. FOOTING CORNER & INTERSECTION REINF.

33 CONCRETE SLAB CONTROL JOINTS TYPICAL

34 TRENCH ADJACENT TO CONCRETE FOOTING

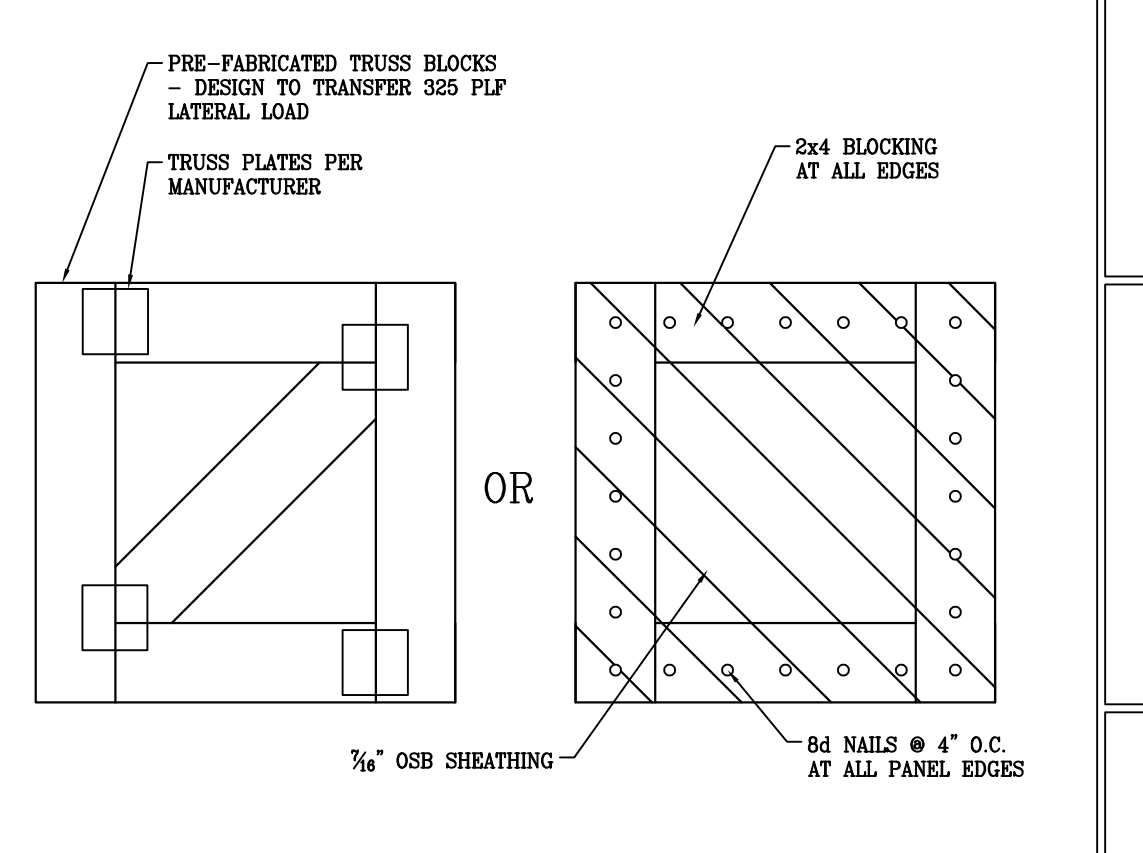
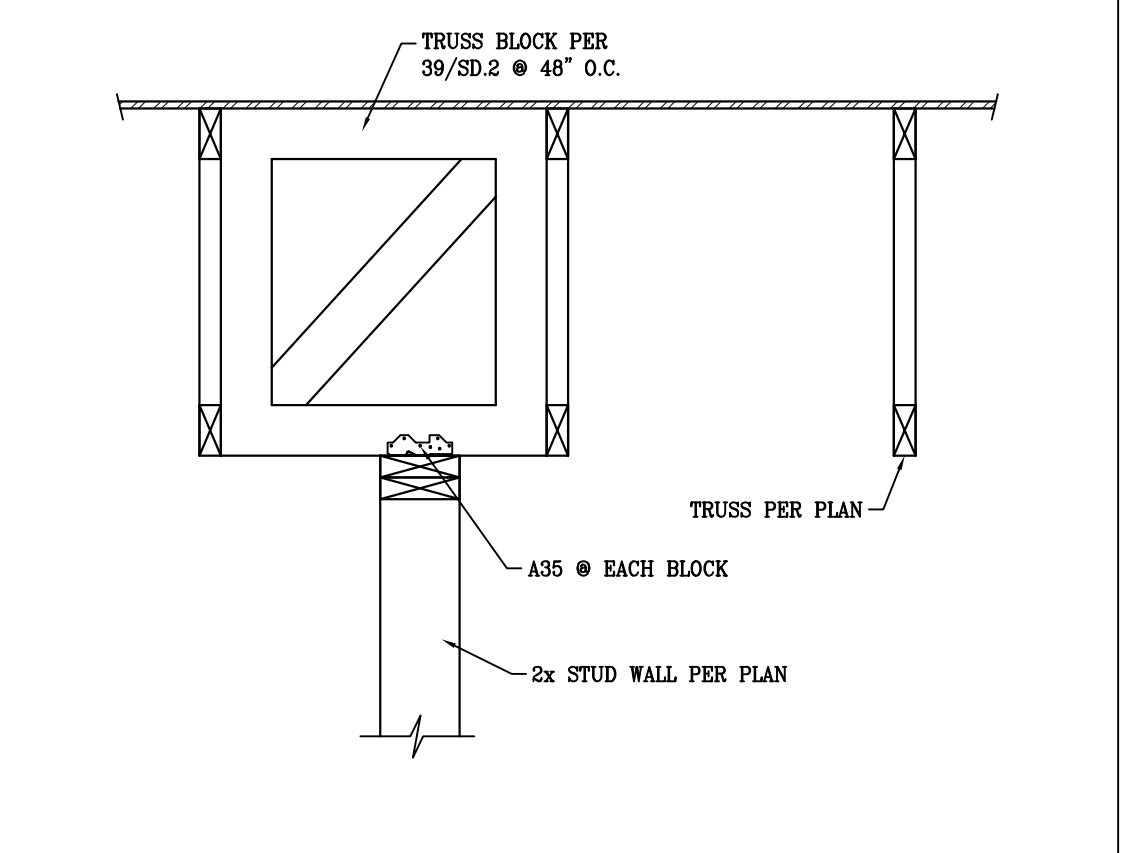
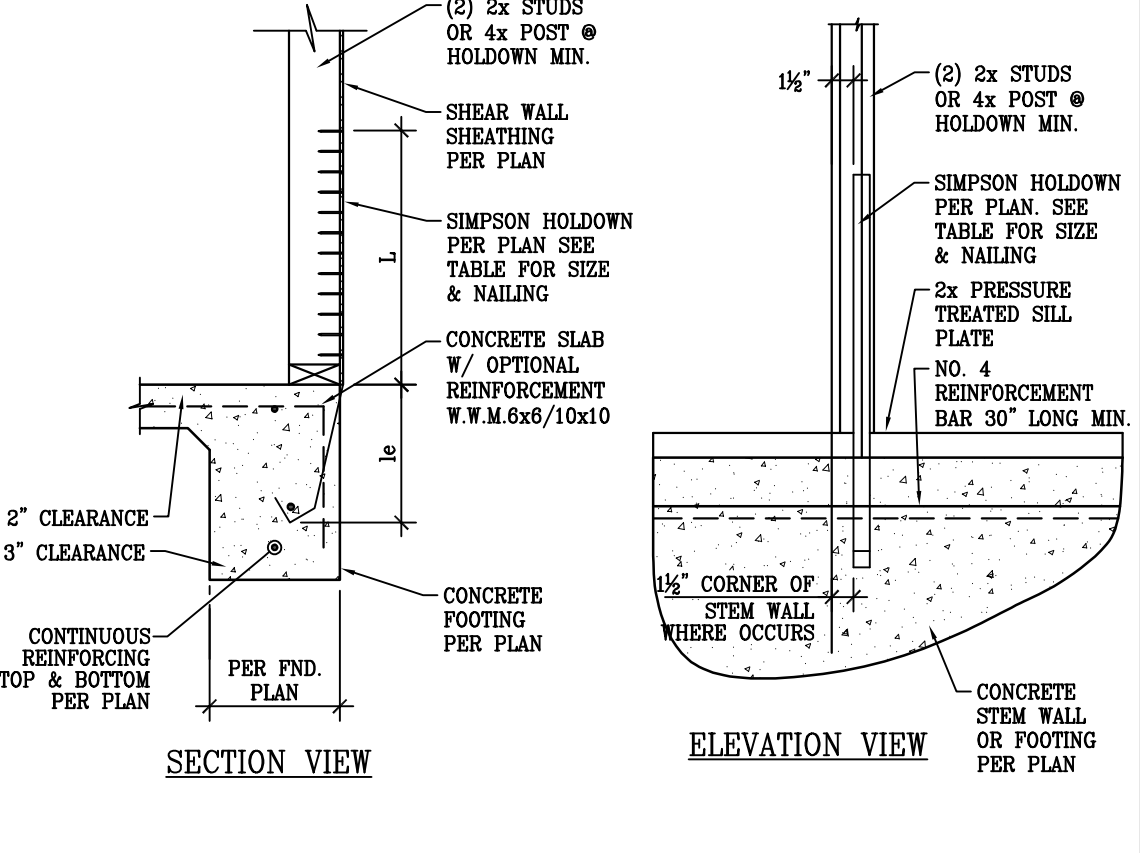
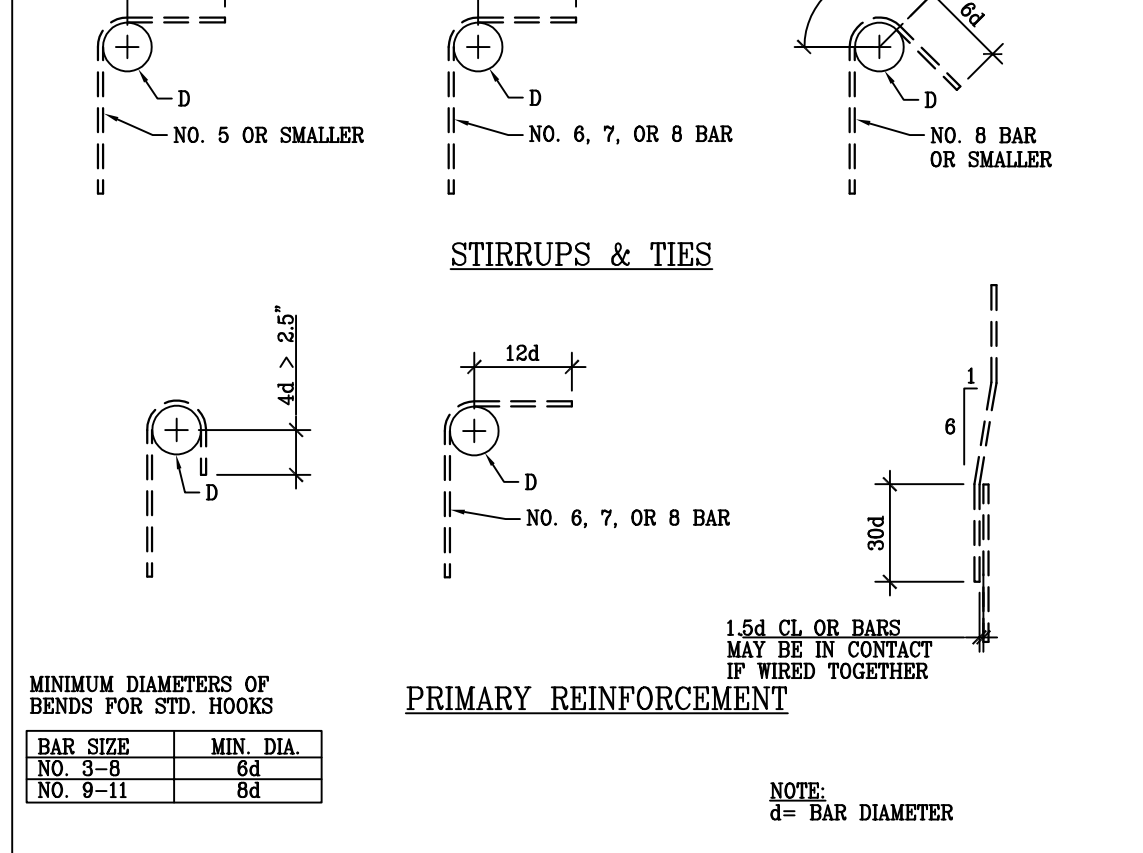
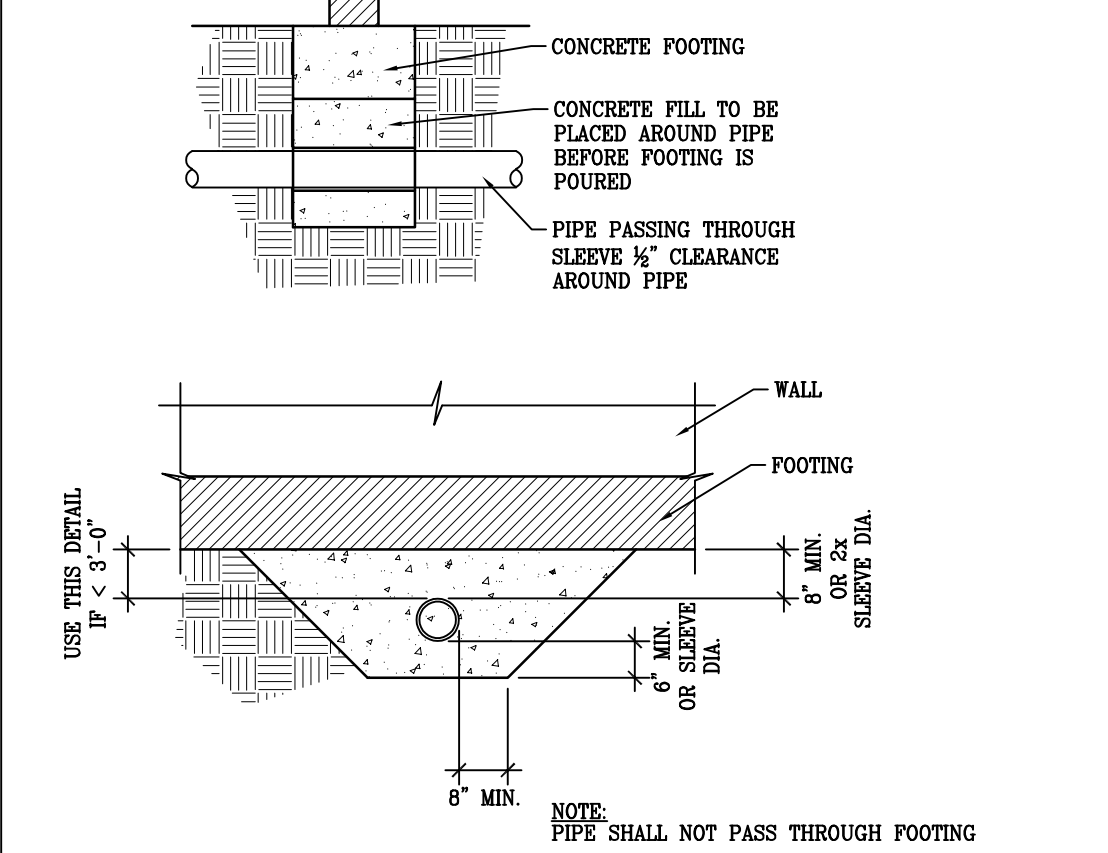

35 PIPE PASSING UNDER CONT. CONC. FOOTING TYP.

36 STANDARD BAR BENDING DETAIL

37 SIMPSON HOLDOWN STRAP CONNECTION TYP.

38 TRUSS OVER STUD WALL

39 TRUSS BLOCKING

2900 AMIGO DRIVE
LAKE HAVASU CITY, ARIZONA

STRUCTURAL DETAILS

DIMENSIONS SHOWN ON THE STRUCTURAL PLANS ARE FOR CONVENIENCE ONLY. VERIFY ALL DIMENSIONS WITH THE CURRENT ARCHITECTURAL PLANS PRIOR TO CONSTRUCTION.

REVISIONS

1	DESCRIPTION	DATE	BY
2			
3			
4			
5			

LEI PROJECT #: 2020-2578
DRAWN BY: EB
CHECKED BY: EB
SCALE: NTS
DATE: 9/17/2020

SHEET
SD.2